

WRL 180H - 650H

Reversible water-cooled heat pump, gas side

Cooling capacity 44,9 + 157,4 kW
 Heating capacity 53,0 + 183,3 kW

- High efficiency
- Suitable for geothermal applications
- Production of hot water up to 55 °C



DESCRIPTION

Water-water offering chilled/hot water, designed to meet air conditioning needs in residential/commercial complexes or industrial applications. Indoor units with hermetic scroll compressors and plate heat exchangers. In the configuration with desuperheater, it is also possible to produce free-hot water.

The technological choices made, always oriented to the highest quality, ensure very easy installation. In fact the electrical and hydraulic connections are all located in the upper part of the unit, facilitating the installation and maintenance operations and also reducing the technical gaps and their position in as little space as possible.

FEATURES

Operating field

Full-load operation with the production of chilled water 4-18 °C, and the possibility to produce also negative temperature water down to -8 °C for the evaporator and hot water for the condenser up to 55 °C. (for more information, refer to the technical documentation).

Plug and play

All the units are equipped with scroll compressors and plate heat exchangers; the base and panelling are made of steel treated with RAL 9003 polyester paints.

The electric and hydraulic connections are all located on the upper part of the unit facilitating installation and maintenance. This allows reduced plant room space and installation in the smallest space possible. The heat pump can be supplied with all the components required for its installation in new systems and to replace other heat generators. It can be combined with low temperature emission systems such as floor heating or fan coils, but also with conventional radiators.

Version with Integrated hydronic kit

The standard unit is supplied with a water filter, differential pressure switch and safety valve already installed on the service and source side (and also on the recovery side, if present).

To obtain a solution that offers economic savings and facilitates installation, these units can be configured with an integrated hydronic kit on both hydraulic sides (service and source). Low-head and high-head pumps are available, along with a modulating 2-way valve that can only be applied on the source side to reduce consumption in applications with groundwater.

CONTROL MPC

Microprocessor adjustment, with keyboard and LCD display, for easy access on the unit is a menu available in several languages.

- Possibility to control two units in a Master-Slave configuration
- The presence of a programmable timer allows functioning time periods and a possible second set-point to be set.
- The temperature control takes place with the integral proportional logic, based on the water output temperature.

ACCESSORIES

AER485P1: RS-485 interface for supervision systems with MODBUS protocol.

AERNET: The device allows the control, the management and the remote monitoring of a Chiller with a PC, smartphone or tablet using Cloud connection. AERNET works as Master while every unit connected is configured as Slave (max. 6 unit); also, with a simple click is possible to save a log file with all the connected unit data in the personal terminal for post analysis.

KSAE: External air sensor.

PGD1: Allows you to control the unit at a distance.

SSM: Probe to be used with the mixer valve in applications with radiant panels. The probe requires the VMF-CRP area accessory as well.

TAH: Ambient terminal with temperature and humidity probe - 230V AC flush-mounting model that can command an On-Off valve or a zone pump and dehumidifier consent.

TAT: Ambient terminal with temperature probe- 230V AC flush-mounting model that can command an On-Off valve or a zone pump.

VMF-CRP: Accessory module for controlling boilers, heat recover units and pumps (if associated with VMF-E5 / RCC panels); if associated with

the VMF-E6 panel, the VMF-CRP modules will be able to manage heat recovery units, RAS, boiler, sanitary management, I/O control, pumps.

VT: Antivibration supports

ACCESSORIES COMPATIBILITY

Model	Ver	180	200	300	400	500	550	600	650
AER485P1	°	*	*	*	*	*	*	*	*
AERNET	°	*	*	*	*	*	*	*	*
KSAE	°	*	*	*	*	*	*	*	*
PGDI	°	*	*	*	*	*	*	*	*
SSM	°	*	*	*	*	*	*	*	*
TAH	°	*	*	*	*	*	*	*	*
TAT	°	*	*	*	*	*	*	*	*
VMF-CRP	°	*	*	*	*	*	*	*	*

Antivibration

Version	Integrated hydronic kit user side	Integrated hydronic kit, source side	180	200	300	400	500	550	600	650
°	'N,P	'B,F,I,U,V	VT9	VT9	VT9	VT9	VT15	VT15	VM	VT15

CONFIGURATOR

Field	Description
1,2,3	WRL
4,5,6	Size 180,200,300, 400, 500,550,600, 650
7	Operating field
°	Standard mechanic thermostatic valve (1)
X	Electronic thermostatic expansion valve
Y	Low temperature mechanic thermostatic valve (2)
8	Model
H	Reversible heat pump, gas side
9	Version
°	Standard
10	Heat recovery
°	Without heat recovery
D	With desuperheater
11	Integrated hydronic kit, source side
°	Without hydronic kit
B	On-off pump

Field	Description
F	Single low-head inverter pump
I	High-head inverter pump
U	Pump high head
Applications with bore hole water	
V	2-way modulating valve
12	Integrated hydronic kit user side
°	Without hydronic kit
N	Pump high head
p	Pump low head
13	Field for future development
°	Field for future development
14	Soft-start
°	Without soft-start
S	With soft-start
15	Power supply
°	400V - 3N 50Hz

(1) Water produced from 4°C + 18°C
(2) Water produced from 4°C + - 8°C

PERFORMANCE SPECIFICATIONS

WRL-^o

Size			180	200	300	400	500	600	650	
Cooling performance 12 °C/ 7 °C (1)										
Cooling capacity	°	kW	44,9	59,6	64,8	79,5	93,0	120,1	140,1	157,4
Input power	°	kW	10,8	14,7	16,3	18,6	20,1	27,6	31,4	35,8
Cooling total input current	°	A	20,0	25,0	28,0	32,0	36,0	52,0	60,0	69,0
EER	°	WW	4,15	4,06	3,97	4,27	4,63	4,34	4,46	4,39
Water flow rate source side	°	l/h	9520	12659	13823	16682	19331	25177	29250	32920
Pressure drop source side	°	kPa	31	52	51	74	34	56	57	71
Water flow rate system side	°	l/h	7732	10274	11168	13711	16013	20686	24139	27112
Pressure drop system side	°	kPa	22	37	36	52	25	40	40	38
Heating performance 40 °C/ 45 °C (2)										
Heating capacity	°	kW	53,0	70,9	76,6	92,6	106,4	143,7	164,2	183,3
Input power	°	kW	12,9	17,7	19,1	22,6	24,0	33,1	37,2	42,7
Heating total input current	°	A	23,0	29,0	31,0	37,0	41,0	56,0	64,0	74,0
COP	°	WW	4,10	4,00	4,01	4,10	4,44	4,34	4,41	4,30
Water flow rate source side	°	l/h	11777	15734	17011	20840	24211	32704	37512	41689
Pressure drop source side	°	kPa	49	89	92	132	61	107	101	126
Water flow rate system side	°	l/h	9190	12277	13264	16046	18452	24913	28485	31788
Pressure drop system side	°	kPa	30	52	49	72	32	58	56	70

(1) Date 14511:2022; Water userside 12 °C / 7 °C; Water source side JO °C / 35 °C
 (2) Date 14511:2022; Water userside 40 °C / 45 °C; Water source side 10 °C / 7 °C

ELECTRIC DATA

Size			180	200	300	400	500	600	650	
Electric data										
Maximum current (FLA)	°	A	32,6	41,8	45,2	52,1	59,0	99,0	112,0	125,0
Peak current (LRA)	°	A	119,0	123,0	125,0	167,0	174,0	265,0	310,0	323,0

ENERGY INDICES (REG. 2016/2281 EU)

Size			180	200	300	400	500	600	650	
SEER • 12/7 (EN14825:2018)(1)										
SEER	°	WW	4,25	4,04	4,15	4,38	5,04	4,62	4,80	4,69
Seasonal efficiency	°	%	166,9%	158,5%	162,8%	172,3%	198,4%	181,7%	188,9%	184,5%
UE 813/2013 performance in average ambient conditions (average) • 55 °C • Pdesignh s 400 kW (2)										
Pdesignh	°	kW	68	91	98	119	137	185	212	236
qsh	°	%	173,0%	170,0%	170,0%	175,0%	189,0%	186,0%	189,0%	184,0%
SCOP	°	WW	4,53	4,45	4,45	4,58	4,93	4,85	4,93	4,80
Efficiency energy class	°	A + tt	-	-	-	-	-	-	-	-
UE 813/2013 performance in average ambient conditions (average) • 35 °C • Pdesignh s 400 kW (3)										
Pdesignh	°	kW	79	-	-	-	-	-	-	-
qsh	°	%	222,0%	-	-	-	-	-	-	-
SCOP	°	WW	5,75	-	-	-	-	-	-	-
Efficiency energy class	°	A + tt	-	-	-	-	-	-	-	-

(1) Calculation performed with FIXED water flow rate and VARIABLE outlet temperature.
 (2) Efficiencies for average temperature applications (55 °C)
 (3) Efficiencies for low temperature applications (35 °C)

GENERAL TECHNICAL DATA

Size		180	200	300	400	500	550	600	650
Compressor									
Type	° type					Scroll			
Compressor modulation	° type					On-Off			
Number	° no.	2	2	2	2	2	2	2	2
Circuits	° no.	1	1	1	1	1	1	1	1
Refrigerant	° type					R410A			
Source side heat exchanger									
Type	° type					Brazed plate			
Number	° no.	1	1	1	1	1	1	1	1
System side heat exchanger									
Type	° type					Brazed plate			
Number	° no.	1	1	1	1	1	1	1	1
Source side hydraulic connections									
Connections (in/out)	° type					Grooved joints			
Sizes (in/out)	°	2"	2"	2"	2"	1 1/2"	2 1/2"	2 1/2"	2 1/2"
System side hydraulic connections									
Connections (in/out)	° type					Grooved joints			
Sizes (in/out)	°	2"	2"	2"	2"	1 1/2"	2 1/2"	2 1/2"	2 1/2"
Sound data calculated in cooling mode (1)									
Sound power level	° dB(A)	61,1	61,8	62,9	71,1	67,6	79,1	79,1	79,1
Sound pressure level (10 m)	° dB(A)	29,6	30,3	31,4	39,6	36,0	47,5	47,5	47,5

(1) Sound power calculated on the basis of measurements made in accordance with UN EN ISO 9614-2, as required for Eurovent certification. Sound pressure (cold functioning) measured in free field, 10m away from the unit external surface (in compliance with UN EN ISO 3744).

DIMENSIONS

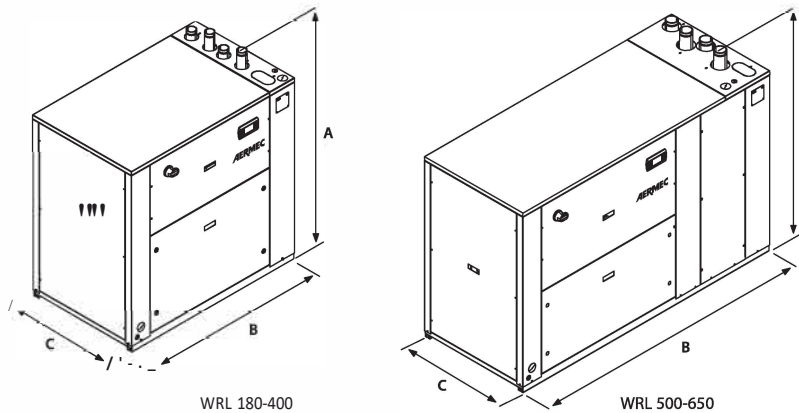

Size		180	200	300	400	500	550	600	650
Dimensions and weights									
A	° mm	1380	1380	1380	1380	1380	1380	1380	1380
B	° mm	1320	1320	1320	1320	2060	2060	2060	2060
C	° mm	845	845	845	845	845	845	845	845
Empty weight	° kg	370	370	381	388	522	598	708	753

Aermec reserves the right to make any modifications deemed necessary. All data is subject to change without notice. Aermec does not assume responsibility or liability for errors or omissions.

Aermec S.p.A.
Via Roma, 996 - 37040 Bevilacqua (VR) - Italia
Tel. 0442633111 - Telefax 044293577
www.aermec.com



WRL 180-650

Water cooled heat pump reversible water side

Cooling capacity 49 + 174 kW
Heating capacity 55 + 192 kW



- High efficiency
- Suitable for geothermal applications
- Production of hot water up to 55 °C



DESCRIPTION

Water-water offering chilled/hot water, designed to meet air conditioning needs in residential/commercial complexes or industrial applications. Indoor units with hermetic scroll compressors and plate heat exchangers. In the configuration with desuperheater, it is also possible to produce free-hot water.

The technological choices made, always oriented to the highest quality, ensure very easy installation. In fact the electrical and hydraulic connections are all located in the upper part of the unit, facilitating the installation and maintenance operations and also reducing the technical gaps and their position in as little space as possible.

FEATURES

Operating field

Full-load operation with the production of chilled water 4-18 °C, and the possibility to produce also negative temperature water down to -8 °C for the evaporator and hot water for the condenser up to 55 °C. (for more information, refer to the technical documentation).

Plug and play

All the units are equipped with scroll compressors and plate heat exchangers; the base and panelling are made of steel treated with RAL 9003 polyester paints.

The electric and hydraulic connections are all located on the upper part of the unit facilitating installation and maintenance. This allows reduced plant room space and installation in the smallest space possible. The heat pump can be supplied with all the components required for its installation in new systems and to replace other heat generators. It can be combined with low temperature emission systems such as floor heating or fan coils, but also with conventional radiators.

Version with Integrated hydronic kit

The standard unit is supplied with a water filter, differential pressure switch and safety valve already installed on the service and source side (and also on the recovery side, if present).

To obtain a solution that offers economic savings and facilitates installation, these units can be configured with an integrated hydronic kit on both hydraulic sides (service and source). Low-head and high-head pumps are available, along with a modulating 2-way valve that can only be applied on the source side to reduce consumption in applications with groundwater.

CONTROL MPC

Microprocessor adjustment, with keyboard and LCD display, for easy access on the unit is a menu available in several languages.

- Possibility to control two units in a Master-Slave configuration
- The presence of a programmable timer allows functioning time periods and a possible second set-point to be set.
- The temperature control takes place with the integral proportional logic, based on the water output temperature.

ACCESSORIES

AER485P1: RS-485 interface for supervision systems with MODBUS protocol.

AERNET: The device allows the control, the management and the remote monitoring of a Chiller with a PC, smartphone or tablet using Cloud connection. AERNET works as Master while every unit connected is configured as Slave (max. 6 unit); also, with a simple click is possible to save a log file with all the connected unit data in the personal terminal for post analysis.

KSAE: External air sensor.

PGD1: Allows you to control the unit at a distance.

SSM: Probe to be used with the mixer valve in applications with radiant panels. The probe requires the VMF-CRP area accessory as well.

TAH: Ambient terminal with temperature and humidity probe - 230V AC flush-mounting model that can command an On-Off valve or a zone pump and dehumidifier consent.

TAT: Ambient terminal with temperature probe- 230V AC flush-mounting model that can command an On-Off valve or a zone pump.

VMF-CRP: Accessory module for controlling boilers, heat recover units and pumps (if associated with VMF-E5 / RCC panels); if associated with

the VMF-E6 panel, the VMF-CRP modules will be able to manage heat recovery units, RAS, boiler, sanitary management, I/O control, pumps.

VT: Antivibration supports

ACCESSORIES COMPATIBILITY

Ver	180	200	300	400	500	550	600	650
Model:*, E, K								
*	AER485P1, AERNET, KSAE, P<DI, SSM, TAH, TAT, VMF-CRP	AER485P1, AERNET, KSAE, P<DI, SSM, TAH, TAT, VMF-CRP	AER485P1, AERNET, KSAE, P<DI, SSM, TAH, TAT, VMF-CRP	AER485P1, AERNET, KSAE, P<DI, SSM, TAH, TAT, VMF-CRP	AER485P1, AERNET, KSAE, P<DI, SSM, TAH, TAT, VMF-CRP	AER485P1, AERNET, KSAE, P<DI, SSM, TAH, TAT, VMF-CRP	AER485P1, AERNET, KSAE, P<DI, SSM, TAH, TAT, VMF-CRP	AER485P1, AERNET, KSAE, P<DI, SSM, TAH, TAT, VMF-CRP

Antivibration

Version	Integrated hydronkkit, sourceside	Integrated hydronic kit user side	180	200	300	400	500	550	600	650
*	'B, f, I, U, V	'N, P	VT9	VT9	VT9	VT9	VT15	VT15	VM	VT15

CONFIGURATOR

Field	Description
1,2,3	WRL
4,5,6	Size 180,200,300, 400, 500,550,600, 650
7	Operating field
*	Standard mechanic thermostatic valve (1)
X	Electronic thermostatic expansion valve
y	Low temperature mechanic thermostatic valve (2)
8	Model
*	Heat pump reversible on the water side
E	Evaporating unit (3)
K	Heat pump reversible on the water side with low pressure drops
9	Version
*	Standard
10	Heat recovery
*	Without heat recovery
D	With desuperheater
11	Integrated hydronic kit, source side
*	Without hydronic kit
B	On-off pump

Field	Description
f	Single low-head inverter pump
I	High-head inverter pump
U	Pump high head
Applications with bore hole water	
V	2-way modulating valve
12	Integrated hydronic kit user side
*	Without hydronic kit
N	Pump high head
p	Pump low head
13	Field for future development
*	field for future development
14	Soft-start
*	Without soft-start
S	With soft-start
15	Power supply
*	400V - 3N 50Hz

- (1) Water produced from 4°C + 18°C
 (2) Water produced from 4°C + - 8°C
 (3) Shipped with holding charge only

PERFORMANCE SPECIFICATIONS

WRL-E

Size		180	200	300	400	500	550	600	650
Cooling performance 12 °C/7°C (1)									
Cooling capacity	kW	46,0	60,1	69,6	80,1	90,6	121,3	140,2	158,7
Input power	kW	12,4	16,0	18,5	19,8	23,1	29,6	34,1	38,5
Cooling total input current	A	23,0	29,0	32,0	36,0	42,0	56,0	65,0	74,0
EER	W/W	3,71	3,76	3,76	4,05	3,92	4,10	4,11	4,12
Water flow rate source side	l/h	7903	10326	11958	13762	15566	20841	24088	27266
Pressure drop system side	kPa	23	39	39	56	25	42	47	57

(1) Service side water 12 °C / 7 °C; Condensing temperature 45 °C

WRL-E'

Size		180	200	300	400	500	550	600	650
Cooling performance 12 °C/7°C (1)									
Cooling capacity	kW	49,7	64,3	74,4	85,9	99,8	129,5	150,1	169,0
Input power	kW	10,8	14,4	16,8	18,3	20,4	27,0	31,0	35,7
Cooling total input current	A	20,0	25,0	29,0	62,0	36,0	51,0	59,0	68,0
EER	W/W	4,59	4,47	4,42	4,69	4,90	4,80	4,84	4,73
Water flow rate source side	l/h	10336	13418	15531	17725	20550	26664	30860	34836
Pressure drop source side	kPa	27	46	62	81	32	52	57	72
Water flow rate system side	l/h	8549	11082	12824	14822	17186	22296	25844	29025
Pressure drop system side	kPa	27	43	46	60	20	49	53	67
Heating performance 40 °C/45 °C (2)									
Heating capacity	kW	55,8	72,6	84,1	95,6	110,7	143,6	166,1	187,7
Input power	kW	13,2	17,6	20,5	22,4	24,8	32,9	37,9	43,9
Heating total input current	A	24,0	30,0	34,0	38,0	44,0	61,0	71,0	82,0
COP	W/W	4,24	4,13	4,10	4,27	4,46	4,36	4,38	4,27
Water flow rate source side	l/h	12542	16257	18813	21745	25213	32709	37914	42683
Pressure drop source side	kPa	58	93	99	129	65	105	114	144
Water flow rate system side	l/h	9685	12580	14561	16557	19196	24909	28816	32553
Pressure drop system side	kPa	24	40	55	71	28	45	50	63

(1) Date 14511.2022; Water userside 12 °C / 7 °C; Water source side 10 °C / 35 °C

(2) Date 14511.2022; Water userside 40 °C / 45 °C; Water source side 10 °C / 7 °C

WRL-K

Size		180	200	300	400	500	550	600	650
Cooling performance 12 °C/7°C (1)									
Cooling capacity	kW	49,7	66,3	76,7	88,6	99,8	111,5	154,6	174,1
Input power	kW	10,8	14,4	16,9	18,3	20,4	26,7	30,8	35,6
Cooling total input current	A	20,0	25,0	29,0	32,0	36,0	51,0	59,0	68,0
EER	W/W	4,59	4,61	4,55	4,85	4,50	5,00	5,02	4,90
Water flow rate source side	l/h	10336	13753	15919	18173	20550	27338	31642	35716
Pressure drop source side	kPa	27	48	65	85	32	55	60	76
Water flow rate system side	l/h	8549	11414	13209	15267	17186	22965	26619	29967
Pressure drop system side	kPa	27	34	42	48	20	24	33	41
Heating performance 40 °C/45 °C (2)									
Heating capacity	kW	55,8	74,3	86,1	97,9	110,7	147,1	170,1	192,1
Input power	kW	13,2	17,5	20,5	22,2	24,8	32,3	37,3	43,1
Heating total input current	A	24,0	30,0	34,0	38,0	44,0	61,0	71,0	82,0
COP	W/W	4,24	4,24	4,20	4,40	4,46	4,56	4,56	4,46
Water flow rate source side	l/h	12542	16745	19337	22397	25213	33690	39052	43963
Pressure drop source side	kPa	58	73	90	103	65	52	71	88
Water flow rate system side	l/h	9685	12876	14904	16953	19196	25504	29507	33331
Pressure drop system side	kPa	24	42	57	74	28	48	52	66

(1) Date 14511.2022; Water userside 12 °C / 7 °C; Water source side 10 °C / 35 °C

(2) Date 14511.2022; Water userside 40 °C / 45 °C; Water source side 10 °C / 7 °C

ENERGY INDICES (REG. 2016/2281 EU)

WRL^o

Size		180	200	300	400	500	550	600	650
SEER •12II (EN14825:2018) (1)									
SEER	WTW	4,65	4,55	4,54	4,74	5,31	5,04	5,12	4,97
Seasonal efficiency	%	182,8%	178,9%	178,5%	186,4%	209,3%	198,7%	201,7%	195,8%
UE 813/2013 performance in awrage ambient conditions (awrage) •55 °c •Pdesignh ≤ 400 kW (2)									
Pdesignh	kW	68	91	98	119	137	185	212	236
ηsh	%	173,0%	170,0%	170,0%	175,0%	189,0%	186,0%	189,0%	184,0%
SCOP	WTW	4,53	4,45	4,45	4,58	4,93	4,85	4,93	4,80
Efficiency energy class		A+++	-	-	-	-	-	-	-
UE 813/2013 performance in awrage ambient conditions (awrage) •35 °C •Pdesignh ≤ 400 kW (3)									
Pdesignh	kW	79	-	-	-	-	-	-	-
ηsh	%	222,0%	-	-	-	-	-	-	-
SCOP	WTW	5,75	-	-	-	-	-	-	-
Efficiency energy class		A+++	-	-	-	-	-	-	-

(1) Calculation performed with FIXED water flow rate and VARIABLE outlet temperature.

(2) Efficiencies for average temperature applications (55 °C)

(3) Efficiencies for low temperature applications (35 °C)

WAK

Size		180	200	300	400	500	550	600	650
SEER •12II (EN14825:2018)(1)									
SEER	WTW	4,65	4,71	4,67	4,90	5,31	5,31	5,35	5,19
Seasonal efficiency	%	182,8%	185,3%	183,6%	192,9%	209,3%	209,2%	210,9%	204,6%
UE 813/2013 performance in awrage ambient conditions (awrage) •55 °c •Pdesignh ≤ 400 kW (2)									
Pdesignh	kW	68	91	98	119	137	185	212	236
ηsh	%	173,0%	170,0%	170,0%	175,0%	189,0%	186,0%	189,0%	184,0%
SCOP	WTW	4,53	4,45	4,45	4,58	4,93	4,85	4,93	4,80
Efficiency energy class		A+++	-	-	-	-	-	-	-
UE 813/2013 performance in awrage ambient conditions (awrage) •35 °c •Pdesignh ≤ 400 kW (3)									
Pdesignh	kW	79	-	-	-	-	-	-	-
ηsh	%	222,0%	-	-	-	-	-	-	-
SCOP	WTW	5,75	-	-	-	-	-	-	-
Efficiency energy class		A+++	-	-	-	-	-	-	-

(1) Calculation performed with FIXED water flow rate and VARIABLE outlet temperature.

(2) Efficiencies for average temperature applications (55 °C)

(3) Efficiencies for low temperature applications (35 °C)

ELECTRIC DATA

Size		180	200	300	400	500	550	600	650
Electric data									
Maximum current (HA)	•E,K	A	32,6	41,8	45,2	52,1	59,0	99,0	125,0
Peakcurrent(LRA)	•E,K	A	119,0	123,0	125,0	167,0	174,0	265,0	310,0

GENERAL TECHNICAL DATA

Size			180	200	300	400	500	550	600	650
Compressor										
Type	'E,K	type	Scroll							
Compressor modulation	'E,K	Type	On-Off							
Number	'E,K	no.	2	2	2	2	2	2	2	2
Cirwits	'E,K	no.	1	1	1	1	1	1	1	1
Refrigerant	'E,K	type	R410A							
Refrigerant charge (1)	'K	kg	6,0	7,0	6,8	7,2	9,0	14,5	16,8	16,5
	E	kg	Holding charge	Holding charge	Holding charge	Holding charge	Holding charge	Holding charge	Holding charge	Holding charge
Source side heat exchanger										
Type	'K	type	Braze plate							
	E	type								
Number	'K	no.	1	1	1	1	1	1	1	1
	E	no.	-	-	-	-	-	-	-	-
System side heat exchanger										
Type	'E,K	type	Braze plate							
Number	'E,K	no.	1	1	1	1	1	1	1	1
Source side hydraulic connections										
Connections (in/out)	'K	Type	Grooved joints							
	E	Type								
Sizes (in/out)	'K	Ø	2"	2"	2"	2"	1 1/2"	2 1/2"	2 1/2"	2 1/2"
	E	Ø								
System side hydraulic connections										
Connections (in/out)	'E,K	Type	Grooved joints							
Sizes (in/out)	'E,K	Ø	2"	2"	2"	2"	1 1/2"	2 1/2"	2 1/2"	2 1/2"
Sound data calculated in cooling mode (2)										
Sound power level	'E,K	dB(A)	61,1	61,8	62,9	71,1	67,6	79,1	79,1	79,1
Sound pressure level (10 m)	'E,K	dB(A)	29,6	30,3	31,4	39,6	36,0	47,5	47,5	47,5

(1) The load indicated in the table is an estimated and preliminary value. The final value of the refrigerant load is indicated on the unit's technical label. For further information contact the office.

(2) Sound power calculated on the basis of measurements made in accordance with UN EN ISO 9614-2, as required for Eurovent certification. Sound pressure (cold functioning) measured in free field, 10m away from the unit external surface (in compliance with UN EN ISO 3744).

DIMENSIONS

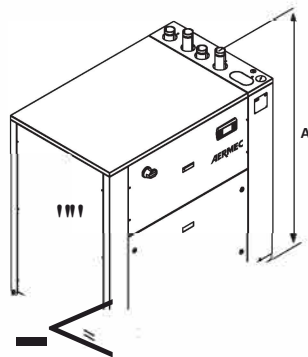

WRL 180-400

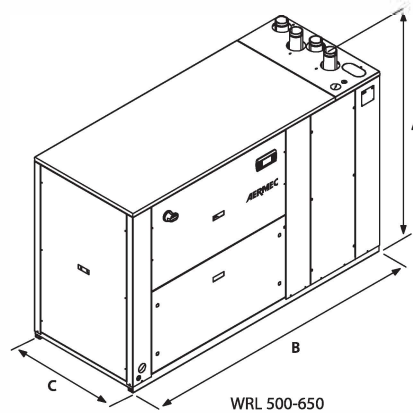

WRL 500-650

Size			180	200	300	400	500	550	600	650
Dimensions and weights										
A	'E,K	mm	1380	1380	1380	1380	1380	1380	1380	1380
B	'E,K	mm	1320	1320	1320	1320	2060	2060	2060	2060
C	'E,K	mm	845	845	845	845	845	845	845	845
Empty weight	'K	kg	375	375	381	388	518	594	670	715
	E	kg	-	-	-	-	-	-	-	-

Aermec reserves the right to make any modifications deemed necessary. All data is subject to change without notice. Aermec does not assume responsibility or liability for errors or omissions.

Aermec S.p.A.
Via Roma, 996 - 37040 Bevilacqua (VR) - Italia
Tel. 0442633111 - Telefax 044293577
www.aermec.com